



## NFPA 58 COMPLIANT LOADING STATIONS



DOT 1075  
PRODUCTS

DOT 1075  
PRODUCTS

MAXIMIZES  
PRODUCT  
FLOW

REMOTE OR  
AUTOMATIC  
SHUTDOWN



TYPE N563 ESV VALVE

### Is Your Loading Station NFPA 58 Compliant?

Most people have no idea about the full requirements of NFPA 58. This is why SafeRack and Fisher have worked together to engineer a fully NFPA 58 compliant loading station.

SafeRack and Fisher have worked together to design a safe and efficient loading system for LPG products (DOT 1075), NGL's or other pressurized gases. This NFPA 58 compliant system provides safe access to the top of railcar, helps maximize product flow and allows for remote or automatic shutdown in case of emergency (fire, leak, railcar rollaway) without requiring an operators / loaders assistance.

Call a SafeRack Representative today to get the facts and see how to make your loading and unloading station NFPA 58 compliant.

### Features

- Full system integration for the loading arm, gangways, cages and ESV connections.
- Ergonomic design to increase efficiency and safety.
- Multiple material trim / seal options for various chemicals available.
- Engineering and Technical support available.
- Remote shut down electrically or pneumatically.

**WORK PLATFORM SOLUTIONS**  
**NFPA COMPLIANT**

**ELEVATION VIEW**

Gangway and loading arm shown in working position

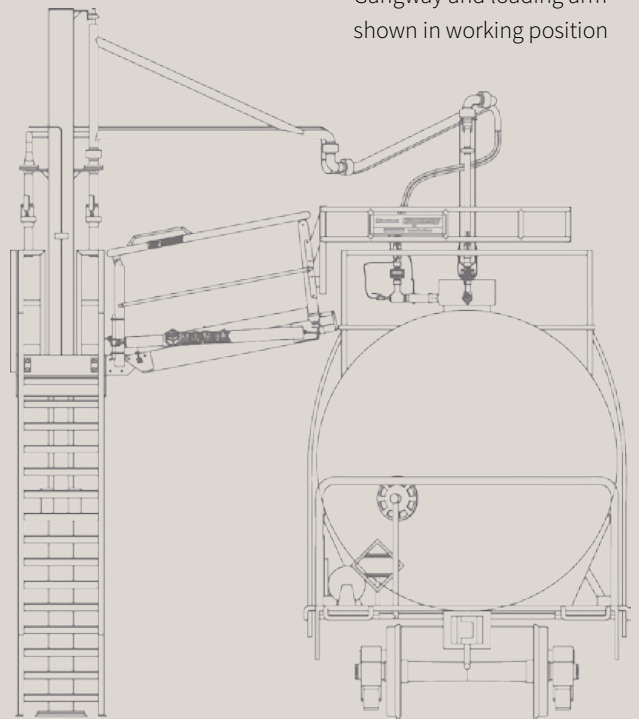
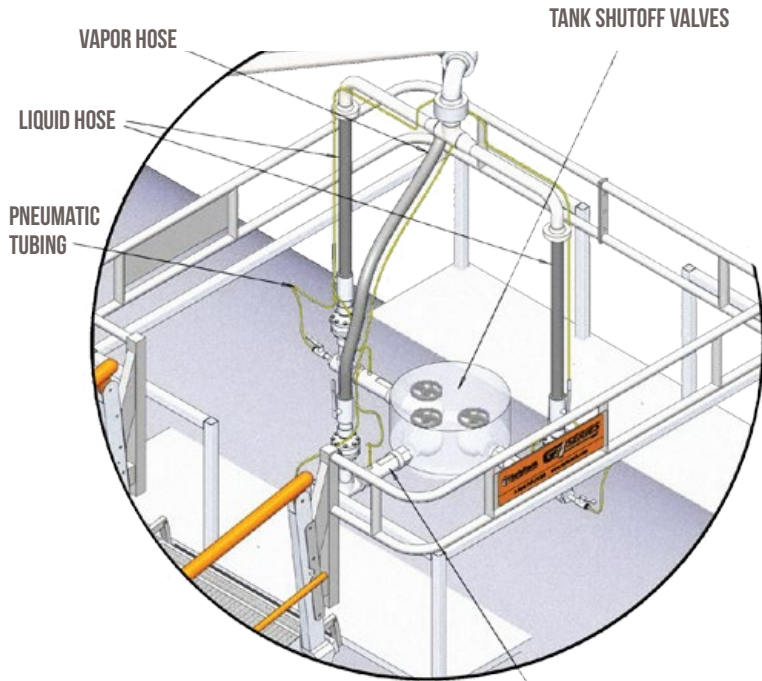

TYPE N563  
 ESV VALVES

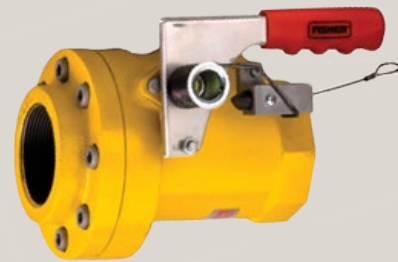
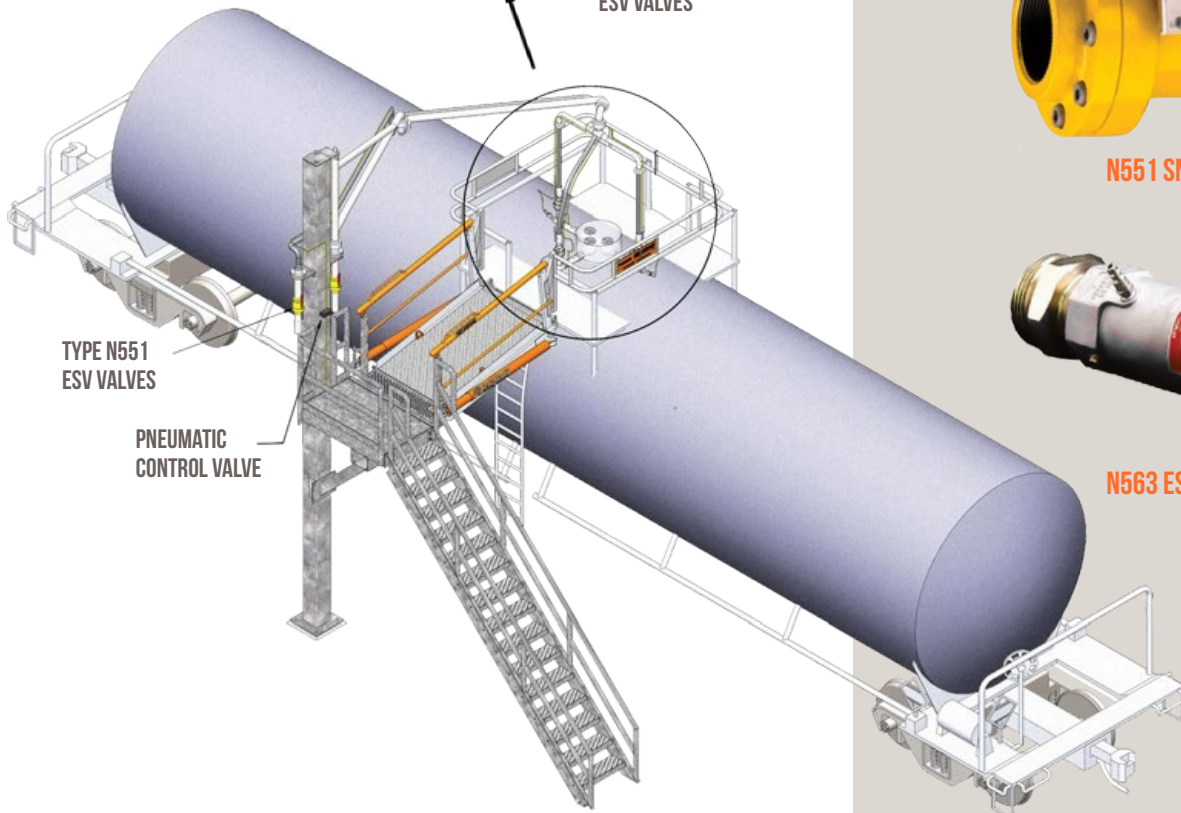

**N551 SNAPPY JOE**



**N563 ESV VALVE**