

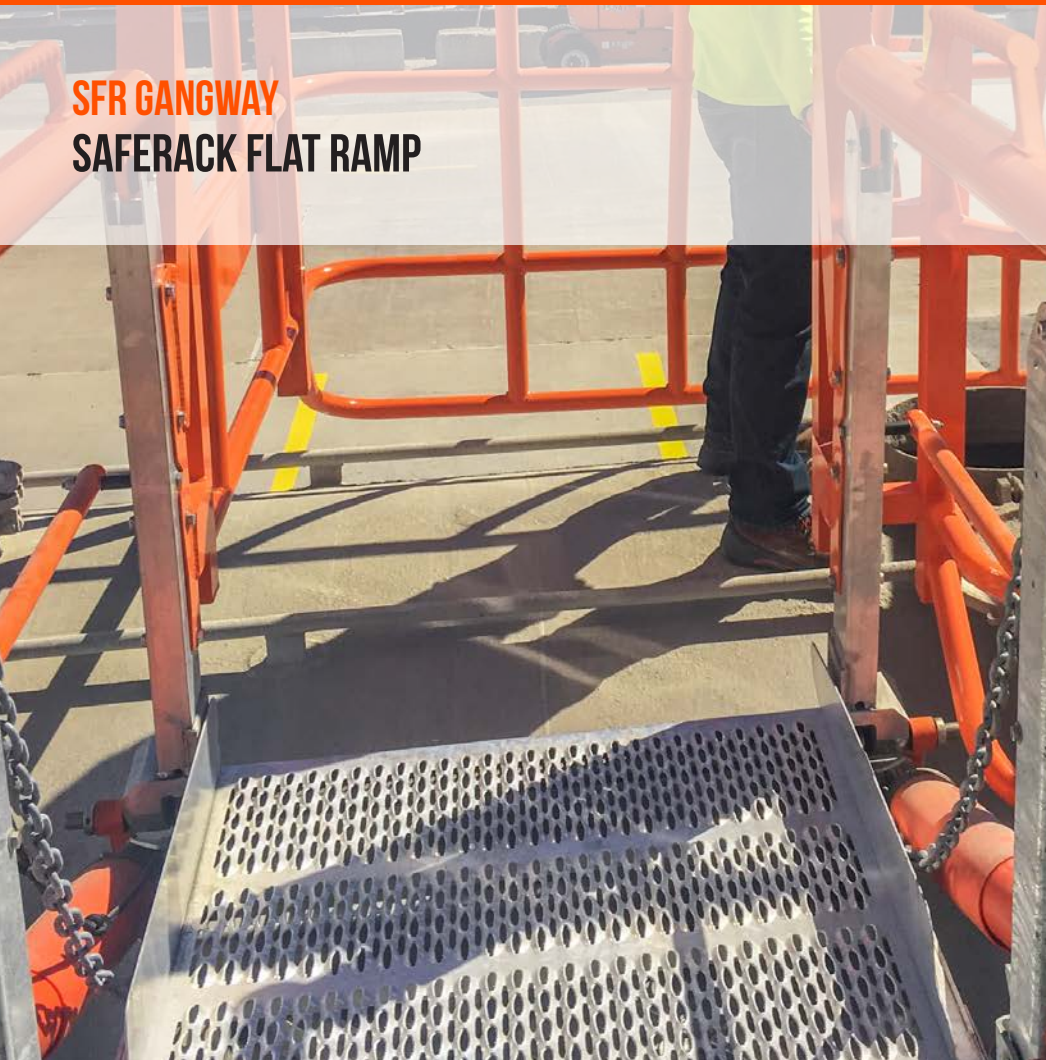

SFR GANGWAY SAFERACK FLAT RAMP



INNOVATIVE
ENGINEERING

OSHA
COMPLIANT

DURABLE,
SAFE & EASY
TO USE



(SFR) SafeRack Flat Ramp Gangway

Our Flat Ramp (SFR) Gangways are constructed with an extra strong tube design for cage mounting. Available in 24", 36", 48", 60" and 72" widths and numerous lengths to fit your application needs. Working range of 15 degrees below and 15 degrees above horizontal. Featuring a slip-resistant walk surface. Popular for hopper car and some truck applications, this model works best when there is little to no difference between the platform height and vehicle height.

All models come standard with rubber bumpers for vehicle protection, machine-quality pivot points and a hot-dipped galvanized steel base tread. Constructed with 1" stainless-steel-bearing-quality pivot rods through its entire length, as well as with machine-quality pivot points. In other words, they're built for both safety and longevity.

SafeRack's SFR gangway is designed to be more ergonomic and longer lasting. Tested in the most critical applications, these gangways outperform all others. Adding fall protection cages is easy, and customized designs are available to meet difficult applications.

REPLACEMENT PARTS & TERMINOLOGY



DIMENSIONS



FEATURES

- Total load capacity 500lbs, Handrails 200lbs
- Available working range 15° above to 15° below horizontal
- One piece extruded handrail with finger grip grab bar
- Base tread hot dipped galvanized per ASTM A-123, Gangway body constructed of aluminum (stainless steel optional)
- Self supporting by use of adjustable chain stops
- Spring counterbalanced for ease of operation
- Load bearing pivot points contain oil impregnated bronze bearings
- Spring counterbalanced for ease of use, with precise field adjustment capability
- Ergonomic and high visibility footlock, to secure gangway in stored position
- Gangways meet AWS D1.1 steel, AWS D1.2 aluminum and AWS D1.6 stainless steel as well as CWB 47.1 steel and CWB 47.2 aluminum
- All critical hardware is stainless steel

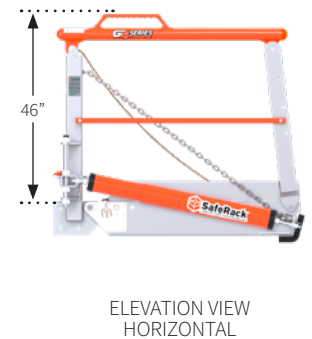
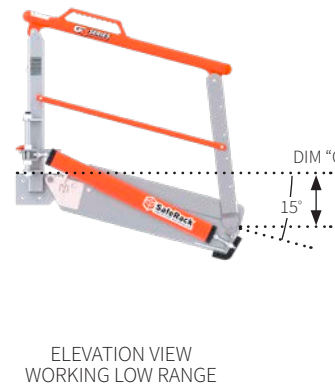
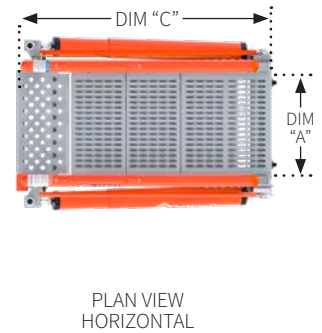
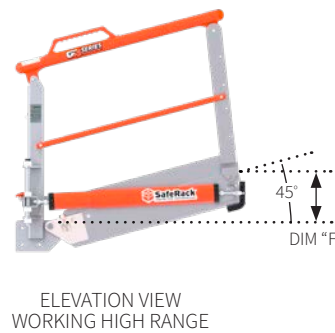

Model #	A	B	Step #	C	D	E	F	G
24	24in	42in	3 Step	36in	20in	65in	7in	7in
36	36in	54in	4 Step	49in	21in	78in	10in	10in
48	48in	66in	5 Step	62in	22in	91in	13in	13in
60	60in	78in	6 Step	75in	24in	104in	17in	17in
72	72in	90in	7 Step	88in	25in	117in	20in	20in



SAS-FRT-SFR GANGWAY STANDARD MOUNTING



STANDARD MOUNTING HOLES IN BACK OF BASETREAD – SEE STANDARD MOUNTING HOLE DIMENSIONS

STANDARD MOUNTING HOLE DIMENSIONS

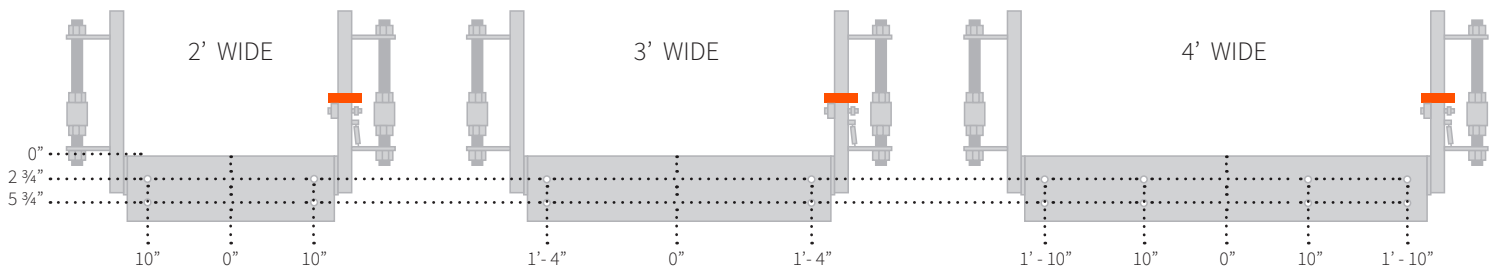

ALL MOUNTING HOLES
13/16" DIA. FOR 3/4" A325 BOLTS

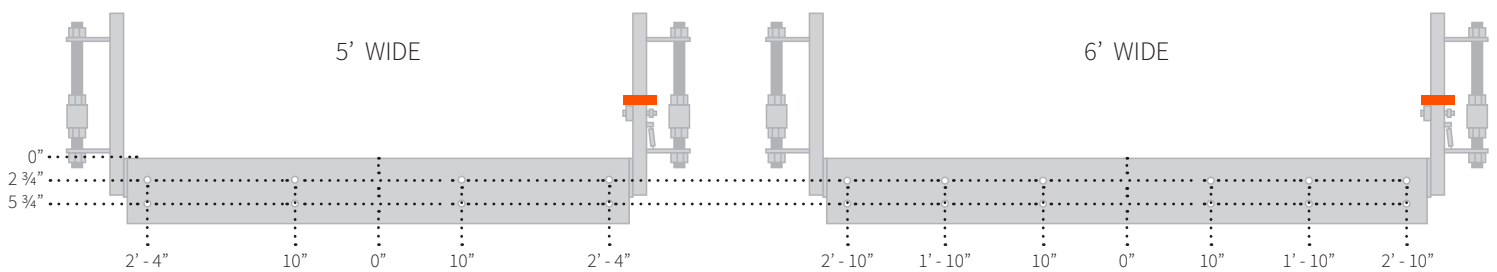

OPTIONAL MOUNTING SMALL ANGLE CLIP

Angle clip both sides of basetread



TOP MOUNT

WHEN TOP MOUNTING HARDWARE MUST GO THROUGH PLATFORM STRUCTURE NOT JUST GRATING

Angle clip both sides of basetread



FRONT SIDE MOUNT

Raised angle clip both sides of basetread



FRONT RAISED SIDE MOUNT

OPTIONAL MOUNTING UNIVERSAL ANGLE CLIP

Universal clip both sides of basetread



BEAM WITH FLUSH GRATING

Universal clip both sides of basetread



CHANNEL WITH FLUSH GRATING

Universal clip both sides of basetread



BEAM WITH TOP GRATING

Universal clip both sides of basetread



CHANNEL WITH TOP GRATING

MOUNTING OPTIONS FOR UNIVERSAL ANGLE CLIP USING HOLES ON THE SIDES OF THE BASETREAD