



REVOLUTIONARY POWER ASSIST SYSTEM LIFT, LOWER & LOCK IN ANY POSITION AUTOMATICALLY

3 POWER
OPTIONS

NO HEAVY
LIFTING

LOCKS IN
ANY POSITION



OVER 200K BACK INJURIES PER YEAR

According to the federal Bureau of Labor Statistics, back injuries account for nearly 20 percent of lost time in the workplace, second only to the common cold. The General Duty Clause of the OSHA act of 1970 requires employers to provide employees with a workplace that is free of recognized hazards. The GX Retractalok lifts and lowers the gangway with the simple press of a pedal or pull of a rope switch—no straining or heavy lifting while loading by rail or truck.

AUTOMATIC LOCK ELIMINATES SAFETY OVERRIDES

Retractalok power assist utilizes an automatic locking feature so operators can't override your safety systems when mis-spotting occurs. The gangway remains safe in any position, prohibiting movement and ensuring the safety of your operators and drivers when loading or unloading by truck or rail.

POWERED LIFT & LOWER SYSTEM

Improved ergonomics eliminate back strain for healthier employees and a safer workplace.

POSITIVE LOCKING SYSTEM

Protects drivers and operators by automatically locking in any position.

PLUG AND PLAY

Factory Installed, pre-set and calibrated for fast and easy installation.

MULTIPLE POWER OPTIONS

Retractalok can be powered by pneumatic, electric, and solar options.

PATENT PENDING

SIMPLE & SAFE TO LIFT OR LOWER

Retractalok power assist eliminates heavy lifting while also addressing gangway springs failure by removing the springs altogether. Lift or lower easily with the press of the foot pedal or pull of the rope switch. The automatic locking feature keeps operators safe in any position and eliminates the possibility of overriding the gangway or cage safety systems while the operator is on top of the railcar or truck.



3 POWER OPTIONS



80 PSI AT A 25 SCFM
AIR PRESSURE REQUIRED

FILTER REGULATOR UNIT WITH
3/8 NPT INLET PORT INCLUDED



12 VOLT DC AMP SYSTEM
240 VOLT OPTION
OR
110 VOLT OPTION

110 VOLT OPTION INCLUDES TRICKLE
CHARGING SYSTEM WITH HIGHEND
INDUSTRIAL BATTERY STORAGE

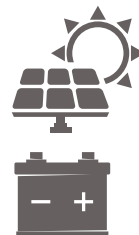
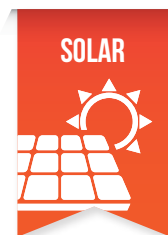

100WATT SOLAR PANEL

INCLUDES 110 VOLT TRICKLE CHARGING
SYSTEM WITH HIGHEND INDUSTRIAL
BATTERY STORAGE

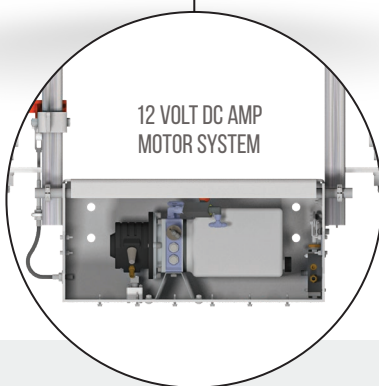

OPTIONAL CORROSION RESISTANT PACKAGE
(PNEUMATIC POWERED ONLY)

Corrosion resistant pneumatic powered system deploys upgraded stainless steel valves and fittings, as well as enhanced epoxy coatings on critical service components.